

S3 TYPE--HC-49/USS PACKAGE
Standard Specifications

Frequency Range (MHz)	8.000~70.000
Mode of Vibration	8.000~30.000MHz Fundamental 27.000~70.000MHz 3 rd Overtone
Drive Level (mW)	0.1 TYPICAL
Load Capacitance (pF)	8.0Pf MIN
Frequency Tolerance (ppm)	± 10、 ± 30、 ± 50(at 25 °C)
Shunt Capacitance(pF)	7 MAX
Operating Temperature Range	0°C ~+70°C Standard
Frequency Stability (refer to 25°C)	± 30ppm Standard
Storage Temperature Range	-40°C ~+85°C
Aging (First Year)	± 5ppm(at 25°C)

Equivalent Series Resistance

Frequency Range (MHz)	ESR MAX (Ω)	Frequency Range (MHz)	ESR MAX (Ω)
8.000~8.999	80	20.000~30.999	30
9.000~12.999	60	27.000~70.000	100
13.000~19.999	40		

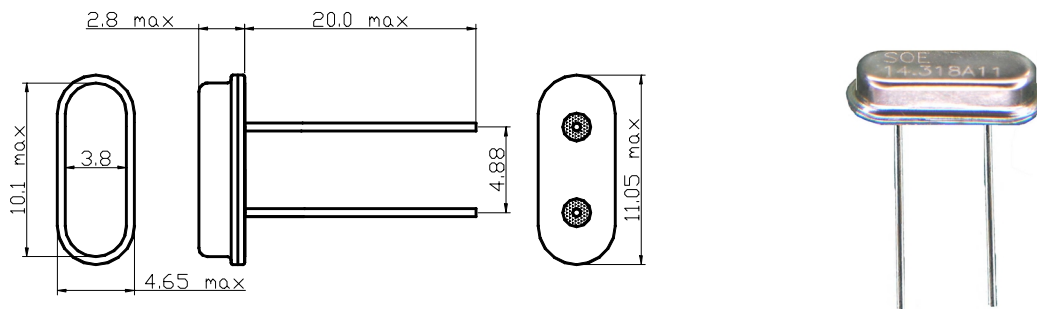

All Dimensions in mm